

MODEL 3900

Up-flow Brine

Service Manual

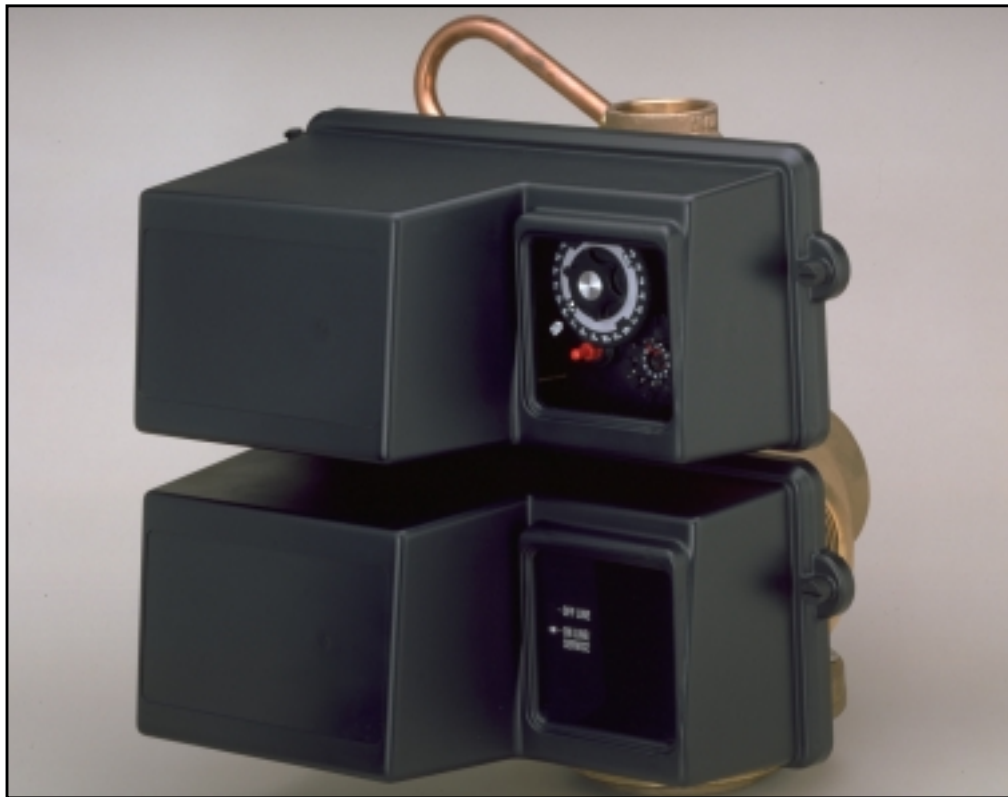

IMPORTANT: Fill in pertinent information on page 2 for future reference.

MODEL 3900 UP-FLOW

Job Specification Sheet

- JOB NO. _____
- *MODEL NO. _____
- WATER TEST _____
- CAPACITY PER UNIT _____ MAX. _____ PER REGENERATION
- MINERAL TANK SIZE DIA. _____ HEIGHT _____
- BRINE TANK SIZE & SALT SETTING PER REGENERATION:

- CONTROL VALVE SPECIFICATIONS

1. Type of Timer (see pages 18-21)

- A. 7 day or 12 day
- B. * 3,750 to 63,750 gallon meter or
* 18,750 to 318,750 gallon meter or
* Other _____

- C. Meter Wiring Package

- 1) System #4 - 1 tank; 1 meter; immediate or delayed regeneration
- 2) System #5 - 2 tanks; 2 meters; interlock
- 3) System #6 - 2 tanks; 1 meter; series regeneration
- 4) System #7 - 2 tanks; 1 meter; alternator

2. Timer Program Settings (see pages 18 and 19)

- A. Backwash _____ min.
- B. Brine & Slow Rinse _____ min.
- C. Rapid Rinse _____ min.
- D. Brine Tank Refill _____ min.

3. Drain Line Flow Controller _____ gpm

4. Brine Line Flow Controller _____ gpm

5. Injector Size # _____

6. A. Hard Water By-Pass
B. No Hard Water By-Pass

MODEL 3900 UP-FLOW

General Commercial Pre-Installation Check List

WATER PRESSURE: A minimum of 25 pounds of water pressure is required for regeneration valve to operate effectively.

ELECTRICAL FACILITIES: A continuous 115 volt, 60 Hertz current supply is required. (Other voltages available.) Make certain the current supply is always hot and cannot be turned off with another switch.

EXISTING PLUMBING: Condition of existing plumbing should be free from lime and iron buildup. Piping that is built up heavily with lime and/or iron should be replaced. If piping is clogged with iron, a separate iron filter unit should be installed ahead of the water softener.

LOCATION OF SOFTENER AND DRAIN: The softener should be located close to a drain.

BY-PASS VALVES: Always provide for the installation of a by-pass valve.

CAUTION: Water pressure is not to exceed 120 p.s.i., water temperature is not to exceed 110°F, and the unit cannot be subjected to freezing conditions.

INSTALLATION INSTRUCTIONS

1. Place the softener tank where you want to install the unit making sure the unit is level and on a firm base. (Maximum 7 feet apart for twin units.) To provide for expansion and contraction of plastic resin tanks and rigid plumbing loads, use FLEXIBLE FITTINGS at the valve.
2. All plumbing should be done in accordance with local plumbing codes. The pipe size for the drain line should be the same size as the drain line flow control connection. Water meters are to be installed on soft water outlets. Twin units with (1) one meter shall be installed on common soft water outlet of units.
3. Make sure that the floor is clean beneath the salt storage tank and that it is level.
4. Place approximately 1" of water above the grid plate (if used) in your salt tank. Salt may be placed in the unit at this time.
5. Place in by-pass position. Turn on the main water supply. Open a cold soft water tap nearby and let run a few minutes or until the system is free from foreign material (usually solder) that may have resulted from the installation.
6. Place the by-pass in service position.
7. Manually index the softener control into service position and let water flow into the mineral tank. When water flow stops, close inlet valve, place control in "brine and rinse" position to relieve head of air, then gradually open inlet valve to purge remaining air in tank. Return control to service position.
8. Electrical: All electrical connections must be connected according to codes. Use electrical conduit if applicable. Plug into power supply.

MODEL 3900 UP-FLOW

Water Conditioner Flow Diagrams

1 SERVICE POSITION

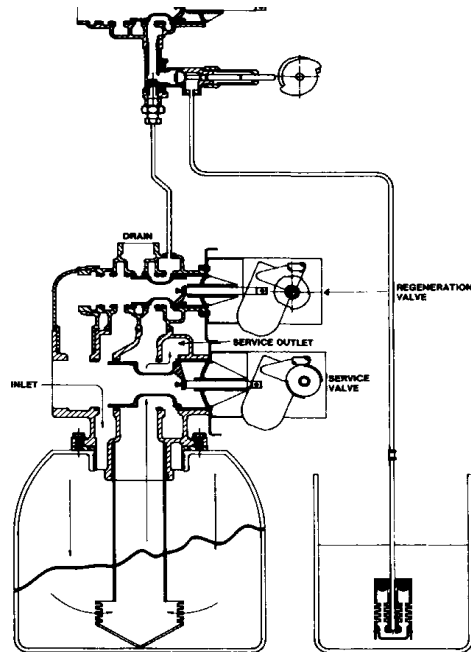

Hard water enters at valve inlet and flows down thru mineral to the bottom distributor.
Conditioned water flows up thru the distributor tube, around the piston and out the outlet.

2 BRINE POSITION

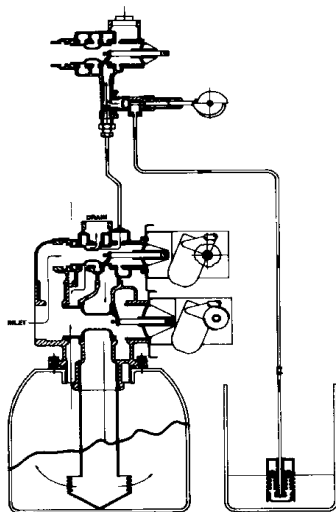

Hard water enters at valve inlet — flows thru the piston to the injector nozzle and throat to draw brine from the brine tank. Brine flows down thru the bottom distributor — up thru the mineral — around the piston and out the drain.

3 SLOW RINSE POSITION

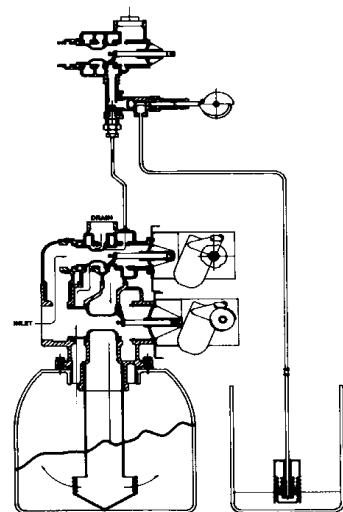

Hard water enters at valve inlet — flows thru the piston to the injector nozzle and throat down thru the bottom distributor — up thru the mineral — around the piston and out the drain.

MODEL 3900 UP-FLOW

Water Conditioner Flow Diagrams (Cont'd.)

4 BACKWASH POSITION

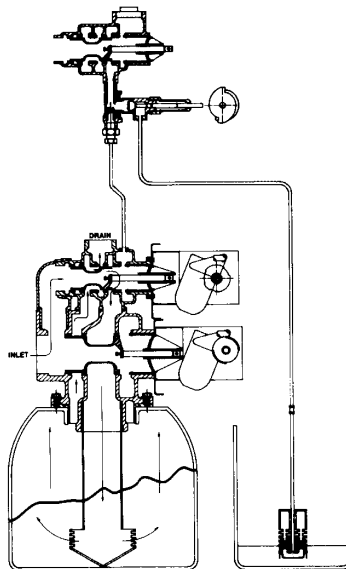

Hard water enters at valve inlet — flows thru service adapter piston for by-pass, and up thru coupling to regeneration valve inlet. Flow continues thru the regeneration valve piston — down the distributor tube — thru the bottom distributor and up thru the mineral — around the piston and out the drain. If optional no hard water by-pass is used, water flow to service outlet is prevented by an extension on the service piston which closes the service outlet until the end of the rapid rinse cycle or brine tank refill cycle, depending on options chosen.

5 RAPID RINSE POSITION

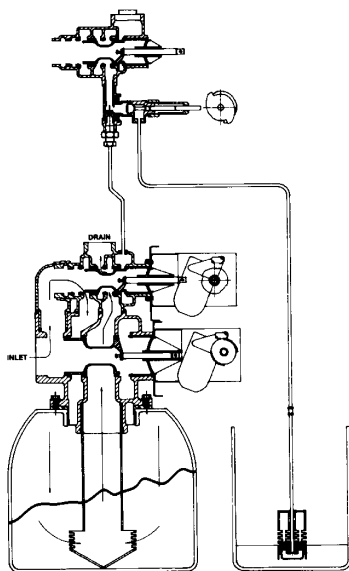

Hard water enters at valve inlet — flows thru the regeneration valve directly down thru the mineral — into the bottom distributor — up the distributor tube - around the piston and out the drain.

6 BRINE TANK REFILL POSITION

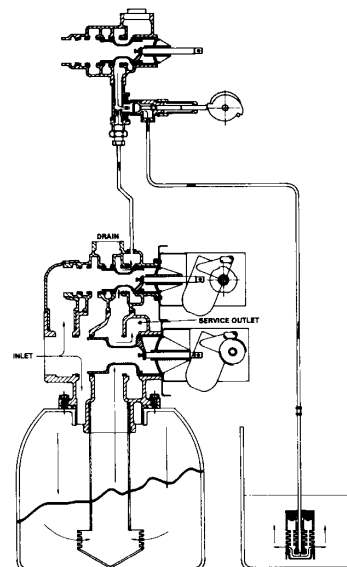

Hard water enters at valve inlet — flows thru the mineral to the bottom distributor — up the distributor to the regeneration valve, to the throat nozzle to fill the brine tank. Conditioned water is also available at the valve outlet. Note: An option is available to keep service valve in by-pass position until the end of brine tank refill cycle.

MODEL 3900 UP-FLOW

Control Valve

(See opposite page for parts list)

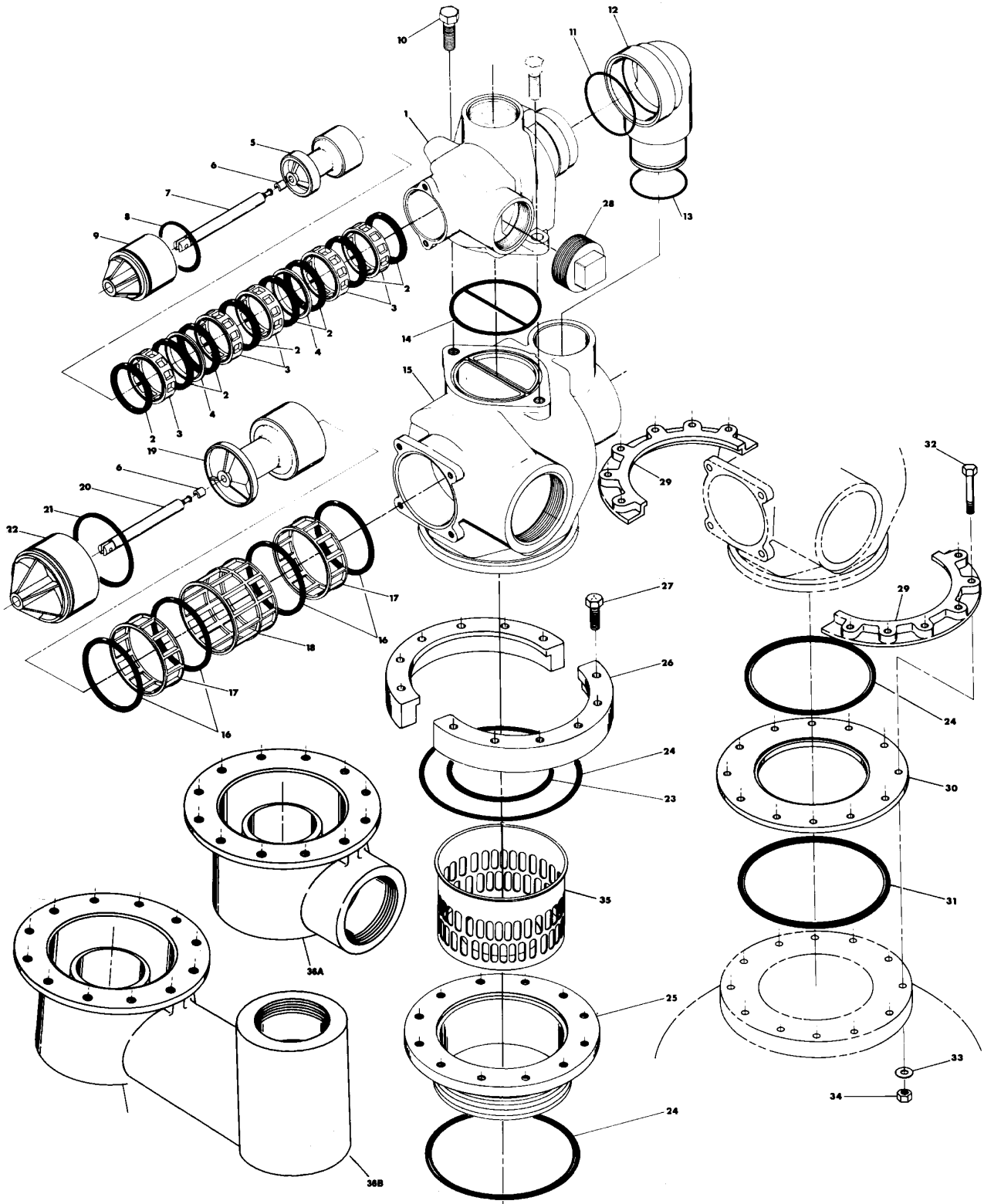

MODEL 3900 UP-FLOW

Control Valve

Parts List

Item No.	No. Req'd.	Part No.	Description
1	1	15114	Valve Body
2	8	11720	Seal
3	5	10369	Spacer - Port
4	2	10368	Spacer
		10368-01	Spacer, Hot Water
5	1	16337	Piston
6	2	14818	Clip - Piston Rod
7	1	15125	Piston Rod
8	1	14922	O-Ring - 035
9	1	16398-21	End Plug Assembly, Gray
10	2	40118	Screw - Hex Hd.
11	1	16078	O-Ring - 149
12	1	16074	Coupling
13	1	16077	O-Ring - 140
14	1	15112	Seal
15	1	16067	3" Adapter Body
16	4	16068	Seal
17	2	16069	Spacer - Narrow
18	1	16070	Spacer - Wide
19	1	16071	Piston
	1	16082	Piston - No Hard Water By-Pass
20	1	16072	Piston Rod
21	1	16076	O-Ring - 042
22	1	16399-01	End Plug Assembly - White
	1	16399-11	End Plug Assembly - Black No Hard Water By-Pass
23	1	16800	O-Ring - 238
24	2	16345	O-Ring - 362
25	1	16255	Tank Adapter - 6" -8
	1	16256	Welded Flange
26	2	16257	Flange Segment
27	12	11238	Screw - Hex Hd.
28	1	16088	Pipe Plug - 2" NPT
35	1	16258	Flow Disperser
Options			
29	2	16482	Flange Segment
30	1	16483	Flange Ring
31	1	16484	O-Ring - 442
32	12	16517	Screw, Park Tank
	12	19592	Screw, Structural Tank
33	12	18619	Washer
34	12	16346	Nut
36B	1	18584	Adapter, Side Mount

MODEL 3900 UP-FLOW

Control Drive Assembly

(See opposite page for parts list)

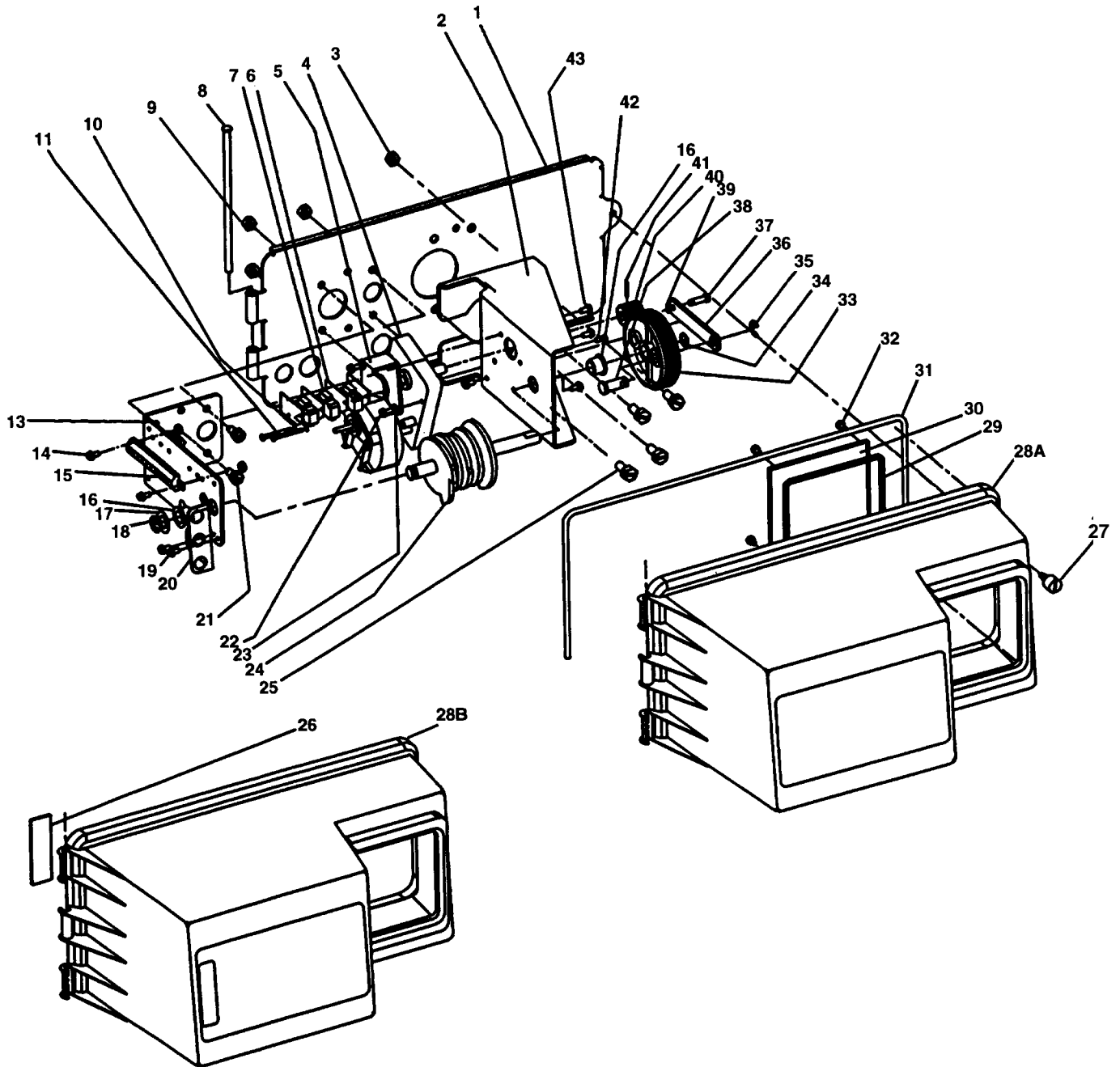

MODEL 3900 UP-FLOW

Control Drive Assembly

Parts List

Item No.	No. Req'd.	Part No.	Description
1	1	19304-00	Back Plate -01, -02
2	1	15120-01	Bracket - Motor Mounting
3	2	16346	Nut - 5/16-18
4	1	16044	Drive Motor - 115 V. 60 Hz.
		16500	Drive Motor - 220 V. 50 Hz.
		16501	Drive Motor - 24 V. 60 Hz.
5	1	17797	Bracket - Switch Mounting
6	4	10302	Insulator - Switch
7	3	10218	Switch
8	1	17845-03	Pin, Hinge
9	4	11235	Nut, 1/4-20
10	2	13365	Lockwasher
11	2	12624	Screw - Pan Hd.
13	1	16053	Bracket - Brine Side
14	2	40133	Screw - Round Hd.
15	1	15226-*	Terminal Block
16	2	16052	Bushing
17	1	16059	Washer
18	1	16051	Retaining Ring - Bowed "E"
•19	2	10300	Screw - Hex Hd. Thread Cutting
•20	1	19317	Light Bracket
21	4	10231	Screw - Hex Hd.
22	2	17567	Screw - Hex Hd.
23	2	12288	Washer, Lock, #8 Internal
24	1	16494-06	Cam Assembly - Service After RR
	1	16494-04	Cam Assembly - Service After Brine Refill
25	4	11224	Screw - Hex Hd.
•26	1	19319	Lamp Window
27	1	18744	Screw
28A	1	19277-020	Cover, Black
•28B	1	19277-021	Cover, Lamp Window
29	1	18615-02	Seal, Window
30	1	18745	Window
31	1	18716-03	Seal, Cover
32	4	19203	Screw
33	1	16046	Drive Gear
34	1	16050	Retaining Ring
35	1	11774	Retaining Ring "E"
36	1	16047	Drive Link
37	1	11709	Pin - Drive Link
38	1	16048	Bearing - Drive Link
39	1	11898	Clip
40	1	16045	Drive Pinion
41	1	11381	Roll Pin
42	1	11080	Screw - Flat Hd.
43	3	10872	Screw - Hex Hd.
44	1		Timer - (not shown) [3000, 3200, 3210, 3200E, 3200ET]
45	1	40084-07	Power Cord, 120V, 7FT (not shown)
	1	40084-12	Power Cord, 120V, 12FT (not shown)
	1	40085-07	Power Cord, 240V, 7FT (not shown)
46	1	17967	Strain Relief (not shown)
47	1	16430	Harness (not shown)
48	1	19691	Hole Plug - 3/4 Dia. (not shown)
49	1	19591	Hole Plug - 7/8 Dia. (not shown)
50	1	16427-04	Motor Lead Wire (not shown)
51	1	16384	Wire Harness (not shown)
52	1	14924	Strain Relief (not shown)
53	1	15513	Meter Cable (not shown)
54	2	15250	Label - Terminal Strip (not shown)
55	1	16821	Cable Guide Assembly (not shown)

* Specify number of terminals

• Optional Parts for Lamp Package

MODEL 3900 UP-FLOW

Adapter Control Drive

(See opposite page for parts list)

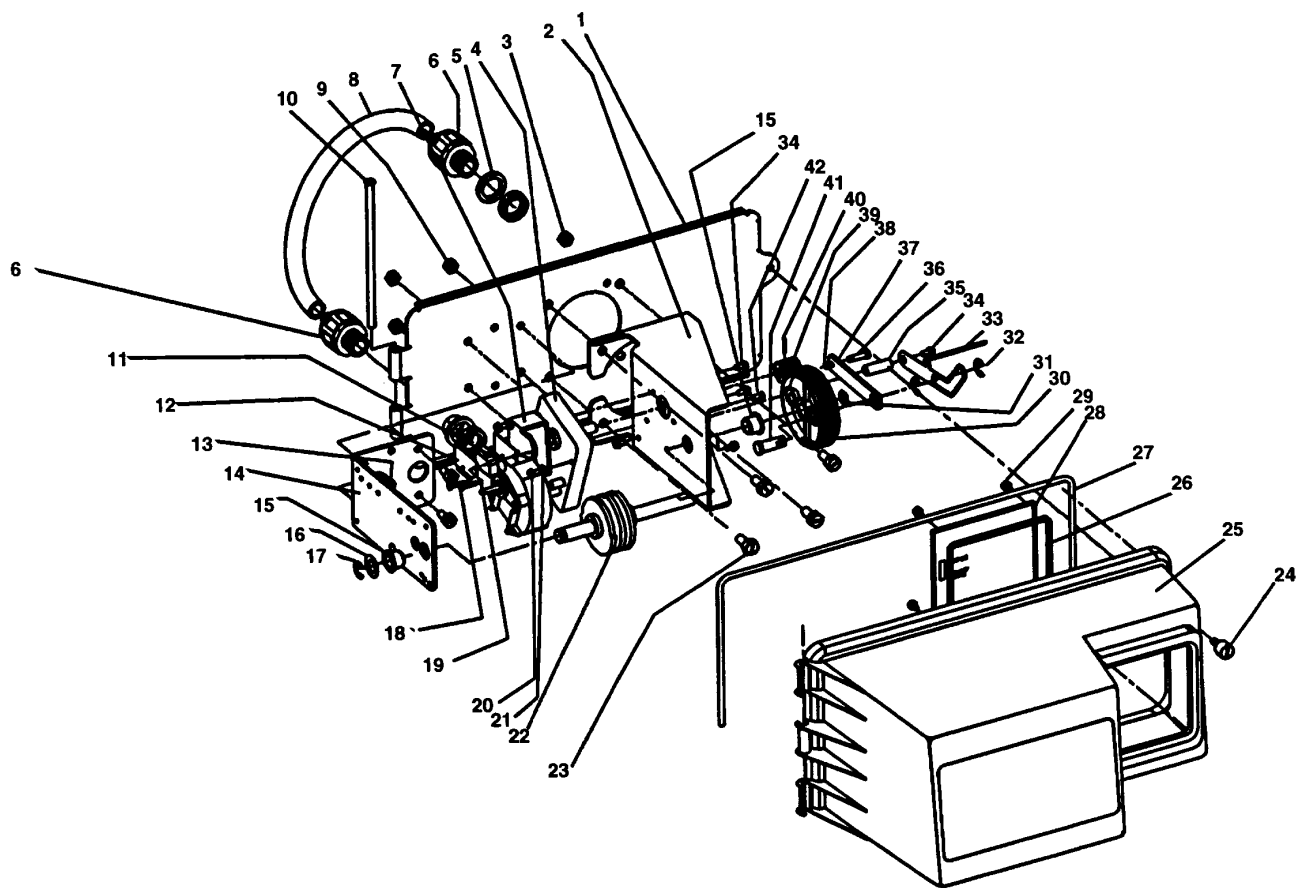

MODEL 3900 UP-FLOW

Adapter Control Drive

Parts List

Item No.	No. Req'd.	Part No.	Description
1	1	19305	Back Plate
2	1	16086	Bracket - Motor Mounting
3	2	16346	Nut
4	1	16044	Drive Motor - 115 V. 60 Hz.
		16500	Drive Motor - 220 V. 50 Hz.
		16501	Drive Motor - 24 V. 60 Hz.
5	2	18692	Washer, Sealing
6	2	18691	Connector, Conduit
7	1	17797	Bracket - Switch Mounting
8	1	18693	Conduit, Interdrive
9	4	11235	Nut, 1/4-20
10	1	17845-03	Pin, Hinge
11	1	10218	Switch
12	2	10302	Insulator - Switch
13	4	10231	Screw - Hex Hd.
14	1	16053	Bracket - Brine Side
15	2	16052	Bushing
16	1	16059	Washer
17	1	16051	Retaining Ring - Bowed "E"
18	2	11805	Screw - Pan Hd.
19	2	13365	Lockwasher
20	2	17567	Screw - Hex Hd.
21	2	12288	Washer, Lock, Internal #8
22	1	16495	Cam Assembly
23	4	11224	Screw - Hex Hd.
24	1	18744	Screw, Cover
25	1	19277-020	Cover, Black
26	1	18615-02	Seal, Window
27	1	18716-03	Seal, Cover
28	1	19316	Window, Indicator
29	4	14430	Screw, Window
30	1	16046	Drive Gear
31	1	16050	Retaining Ring
32	2	11774	Retaining Ring - "E"
33	1	19315	Indicator
34	4	10872	Screw - Hex Hd.
35	1	18726	Space, Indicator
36	1	11709	Pin - Drive Link
37	1	16047	Drive Link
38	1	11898	Clip
39	1	16045	Drive Pinion
40	1	11381	Roll Pin
41	1	16048-01	Bearing - Drive Link
42	2	11080	Screw - Flat Hd.
43	1	19015	Wire Harness (not shown)

MODEL 3900 UP-FLOW

1800 Brine System

(See opposite page for parts list)

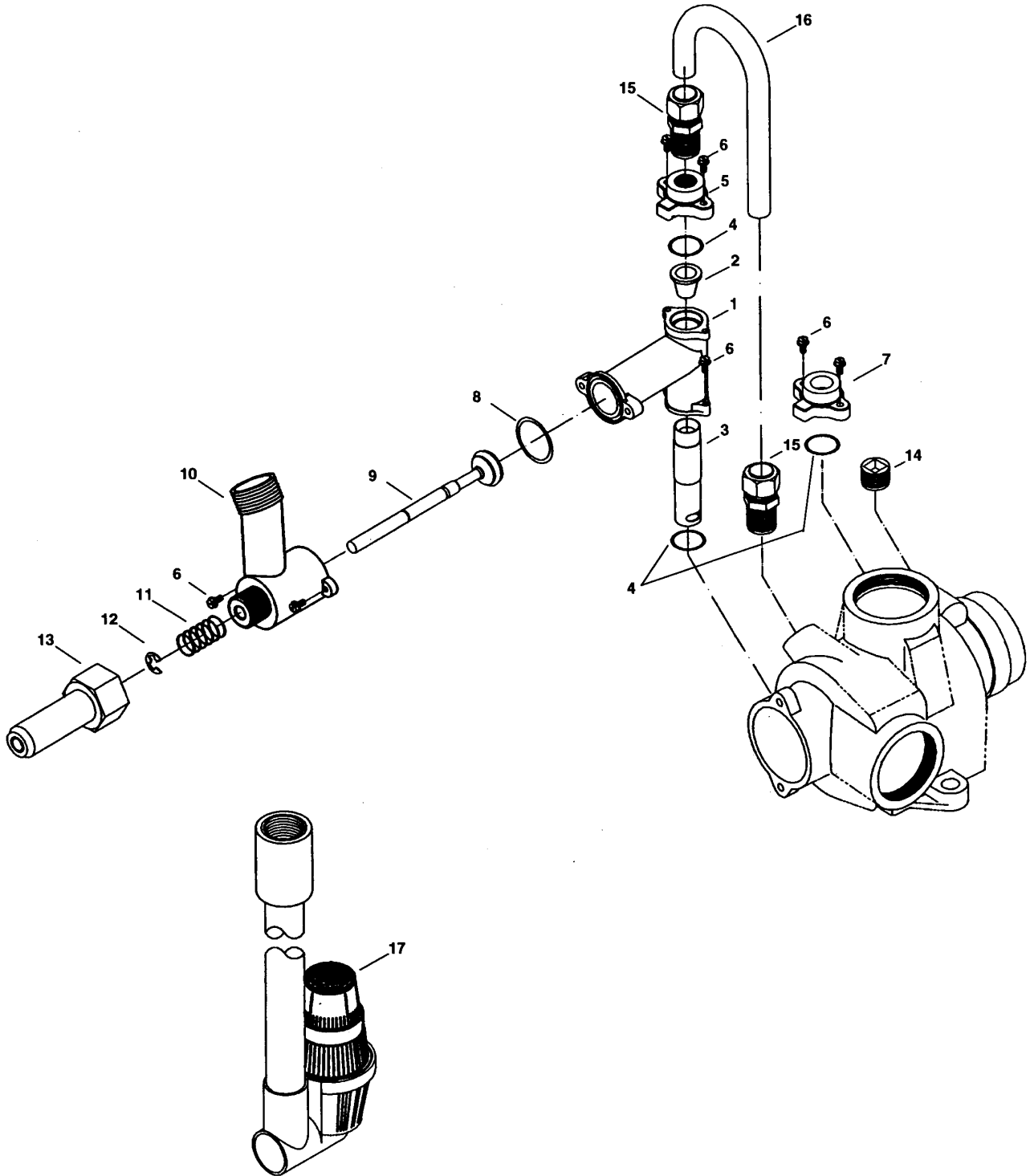

MODEL 3900 UP-FLOW

1800 Brine System

Parts List

Item No.	No. Req'd.	Part No.	Description
1	1	16340-01	Injector Body
2	1	15128-*	Injector Nozzle
3	1	15127-*	Injector Throat
4	3	15246	O-Ring - 116
5	1	16341-01	Injector Cover
6	8	12473	Screw - Hex Hd.
7	1	16341-02	Cover
8	1	18879	O-Ring - 021
9	1	16497-01	Brine Stem Assembly
10	1	18713	Brine Valve Body
11	1	11772	Spring
12	1	11774	Retaining Ring
13	1	16498-01	Stem Guide Assembly
14	1	16387	Pipe Plug - 1/2 NPT
15	2	18702	Tube Fitting - Straight
16	1	18703	Brine Tube
17	1	60009	#900 Commercial Air Check
	1	60009-01	#900 Commercial Air Check Hot Water
18	1		Flow Control - Specify Flow Rate - Not Shown

* Specify size

Option Without Brine Valve

1	16605	Retainer Plate
1	16620	Fitting - Brine Tank
1	18879	O-Ring - 021

Delete: Items 9 thru 16

Injector Throat

15127-04	#4	Green
15127-05	#5	Red
15127-06	#6	White
15127-07	#7	Blue
15127-08	#8	Yellow
15127-09	#9	Violet
15127-10	#10	Black

Injector Nozzle

	Size	Color
15128-04	#4	Green
15128-05	#5	Red
15128-06	#6	White
15128-07	#7	Blue
15128-08	#8	Yellow
15128-09	#9	Violet
15128-10	#10	Black

MODEL 3900

3" Meter Assembly

(See opposite page for parts list)

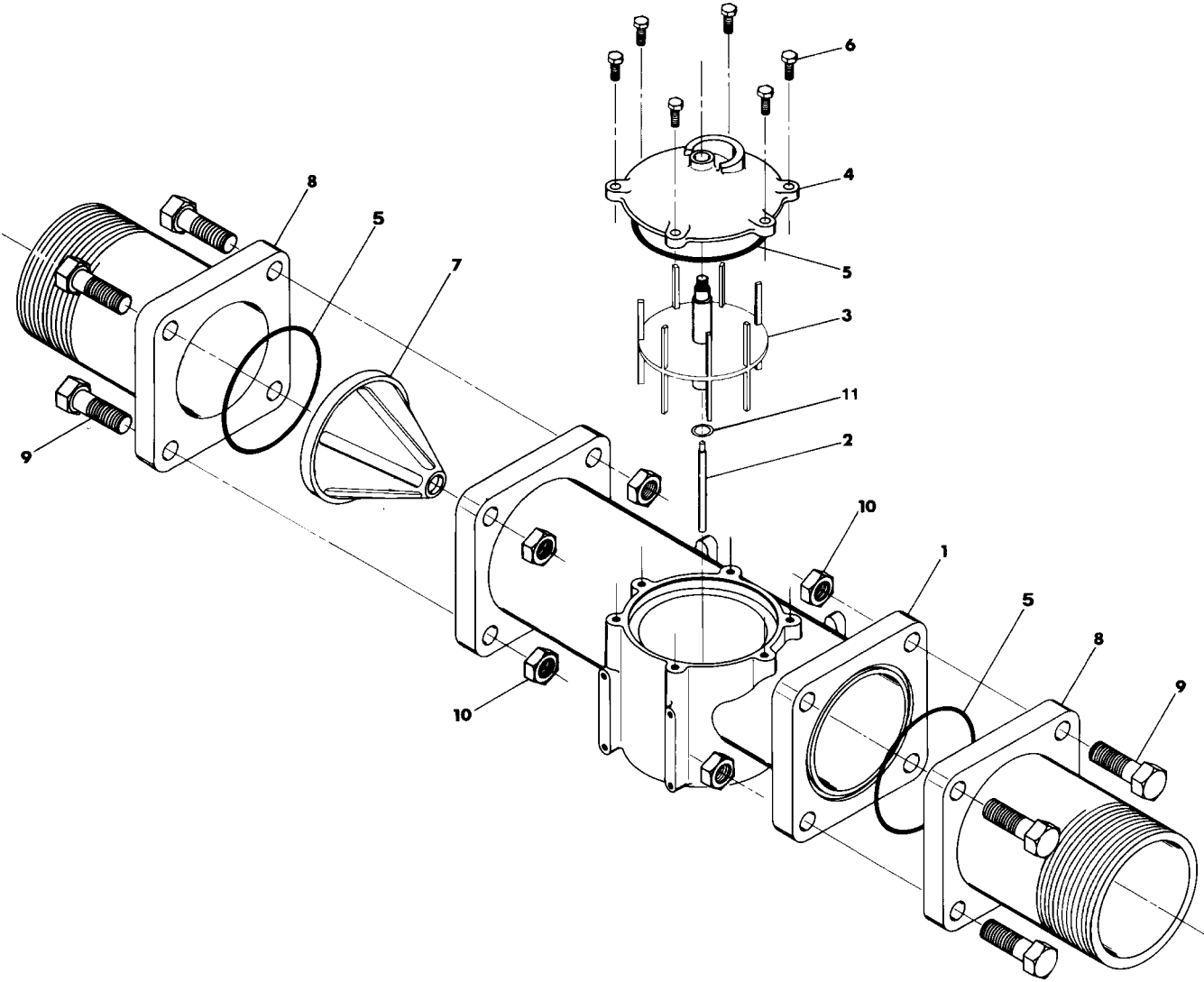

MODEL 3900

3" Meter Assembly

Parts List

Item No.	No. Req'd.	Part No.	Description
1	1	16254	Meter Body
2	1	16279	Impeller Shaft
3	1	16575	Impeller Assembly
4	1	16400	Meter Cover Assembly - Std.
	1	16401	Meter Cover Assembly - Ext. Range
5	3	15707	O-Ring - 236
6	6	12112	Screw - Hex Hd.
7	1	16280	Flow Straightener
8	2	16328	Connecting Flange
9	8	40118	Screw - Hex Hd.
10	8	16386	Nut - 1/2-13
11	1	16574	Stainless Steel Washer

MODEL 3210 ECONOMINDER™

Timer Assembly

(See opposite page for parts list)

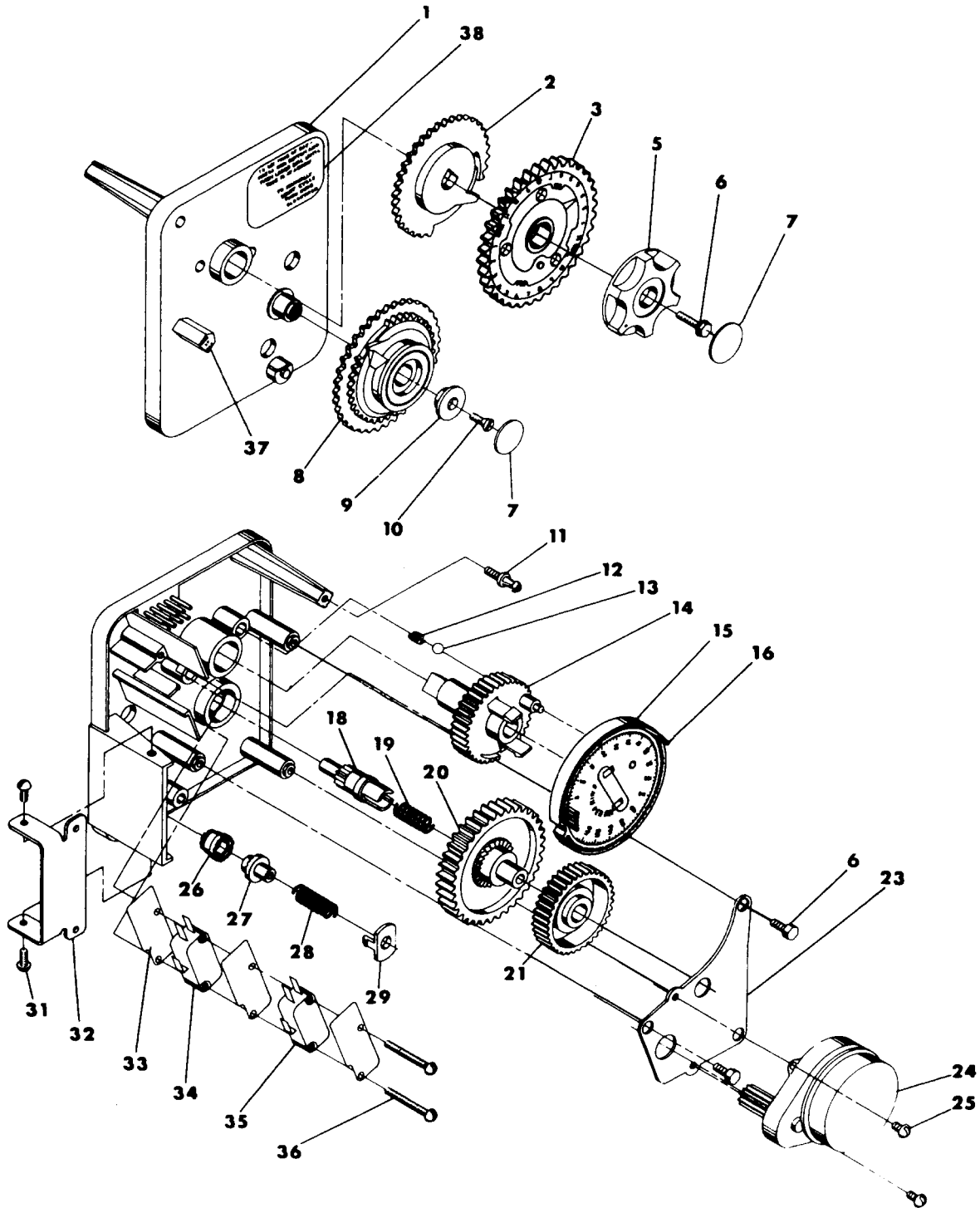

MODEL 3210 ECONOMINDER™

Timer Assembly

Parts List

Item No.	No. Req'd.	Part No.	Description
1	1	13870-01	Timer Housing Assembly
2	1	13802	Cycle Actuator Gear
3	1	40096-27	24 Hour Gear Assy, 12 Midnight
		40096-02	24 Hour Gear Assy, 2 AM
5	1	13886-01	Knob
6	4	13296	Screw - Timer Knob & Motor Plate Mtg.
7	2	11999	Button Decal
8	1	60405-80	Program Wheel Assembly - 0-63,750
9	1	13806	Program Wheel Retainer
10	1	13748	Screw - Program Wheel Mtg.
11	1	14265	Spring Clip
12	1	15424	Spring - Detent
13	1	15066	Ball - 1/4" Dia.
14	1	13911	Main Drive Gear
15	1	19210	Program Wheel
16	21	15493	Roll Pin
18	1	13018	Idler Shaft
19	1	13312	Spring - Idler
20	1	13017	Idler Gear
21	1	13164	Drive Gear
23	1	13887	Motor Mounting Plate
24	1	18743	Motor - 110V., 60Hz.
		19659	Motor - 24V., 60 Hz.
25	2	13278	Screw - Motor Mounting
26	1	13830	Drive Pinion - Program Wheel
27	1	13831	Clutch - Drive Pinion
28	1	14276	Spring
29	1	14253	Spring Retainer
30			Not Assigned
31	3	11384	Screw - Timer Hinge & Ground Wire
32	1	13881	Hinge Bracket
33	3	14087	Insulator
34	1	10896	Switch
35	1	15320	Switch
36	2	11413	Screw - Switch Mounting
37	1	14007	Decal - Time of Day
38	1	14045	Decal - Instructions
39	1	13902	Harness - Not Shown
40	2	12681	Wire Connector - Not Shown
41	1	15354-01	Ground Wire - Not Shown

MODEL 3210 ECONOMINDER™

Commercial Demand Regeneration Control

Timer Settings

Typical Programming Procedure

Calculate the gallon capacity of the system, subtract the necessary reserve requirement and set the gallons required by lifting the gallon dial and rotating it so that the number of gallons required is aligned with the white dot on program wheel gear. Release and check for firm engagement with gear. Note, drawing shows 8,750 gallon setting. The capacity (gallons) arrow denotes remaining gallons exclusive of fixed reserve.

Note:

To set meter capacity at initial start-up, either:

1. Rotate manual regeneration knob one full revolution.
- or -
2. Rotate program wheel manually clockwise or counterclockwise and align white dot with capacity arrow.

This procedure must be followed any time the program wheel setting is changed.

How To Set The Time Of Day:*

Press and hold the red button in to disengage the 24 hour gear.

Turn the 24 hour gear until the actual time of day is at the time of day pointer.

Release the red button to again engage the 24 hour gear.

How To Manually Regenerate Your Water Conditioner At Any Time:

Turn the manual regeneration knob clockwise one "click."

This slight movement of the manual regeneration knob engages the program wheel and starts the regeneration program.

The black center knob will make one revolution in the following approximately three hours and stop in the position shown in the drawing.

Even though it takes three hours for this center knob to complete one revolution, the regeneration cycle of your unit might be set for only one half of this time.

In any event, conditioned water may be drawn after rinse water stops flowing from the water conditioner drain line.

Immediate Regeneration Timers:

These timers do not have a 24 hour gear. Setting the gallons on the program wheel and manual regeneration procedure are the same as previous instructions.

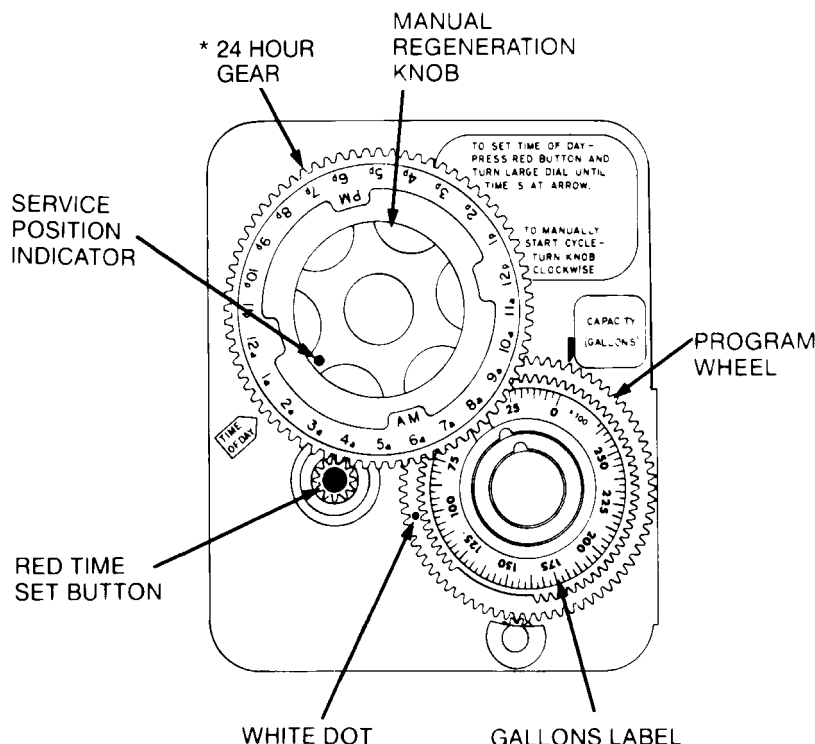

* Immediate regeneration timers do not have 24 hour gear. No time of day can be set.

MODEL 3200 TIMER

Timer Setting Procedure

How to Set Days on Which Water Conditioner is to Regenerate:

Rotate the skipper wheel until the number "1" is at the red pointer. Set the days that regeneration is to occur by sliding tabs on the skipper wheel outward to expose trip fingers. Each tab is one day. Finger at red pointer is tonight. Moving clockwise from the red pointer, extend or retract fingers to obtain the desired regeneration schedule.

How to Set the Time of Day:

Press and hold the red button in to disengage the drive gear.

Turn the large gear until the actual time of day is at the time of day pointer.

Release the red button to again engage the drive gear.

How to Manually Regenerate Your Water Conditioner at Any Time:

Turn the manual regeneration knob clockwise.

This slight movement of the manual regeneration knob engages the program wheel and starts the regeneration program.

The black center knob will make one revolution in the following approximately three hours and stop in the position shown in the drawing.

Even though it takes three hours for this center knob to complete one revolution, the regeneration cycle of your unit might be set only one half of this time.

In any event, conditioned water may be drawn after rinse water stops flowing from the water conditioner drain line.

How to Adjust Regeneration Time:

1. Disconnect the power source.
2. Locate the three screws behind the manual regeneration knob by pushing the red button in and rotating the 24 hour dial until each screw appears in the cut out portion of the manual regeneration knob.
3. Loosen each screw slightly to release the pressure on the time plate from the 24 hour gear.
4. Locate the regeneration time pointer on the inside of the 24 hour dial in the cut out.
5. Turn the time plate so the desired regeneration time aligns next to the raised arrow.
6. Push the red button in and rotate the 24 hour dial. Tighten each of the three screws.
7. Push the red button and locate the pointer one more time to ensure the desired regeneration time is correct.
8. Reset the time of day and restore power to the unit.

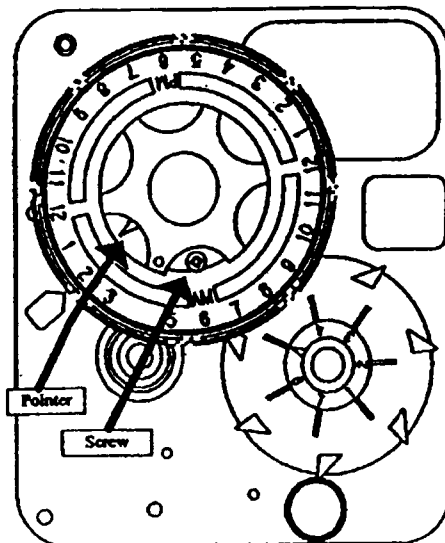
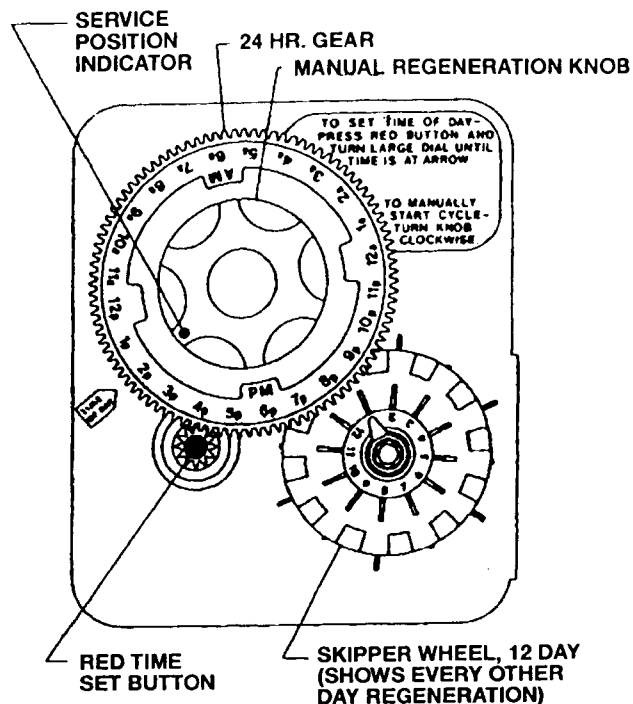

3200 ADJUSTABLE REGENERATION TIMER

IMPORTANT!
SALT LEVEL MUST ALWAYS BE ABOVE
WATER LEVEL IN BRINE TANK.

MODEL 3200 & 3210 TIMER SERIES

Regeneration Cycle Program Setting Procedure

How to Set Regeneration Cycle Program:

The regeneration cycle program on your water conditioner has been factory preset, however, portions of the cycle or program may be lengthened or shortened in time to suit local conditions.

3200 & 3210 Series Timers (Figure to Right)

To expose cycle program wheel, grasp timer in upper left-hand corner and pull, releasing snap retainer and swinging time to the right

To change the regeneration cycle program, the program wheel must be removed. Grasp program wheel and squeeze protruding lugs toward center, lift program wheel off timer. (Switch arms may require movement to facilitate removal.)

Return timer to closed position engaging snap retainer in back plate. Make certain all electrical wires locate above snap retainer post.

Timer Setting Procedure for 3200 & 3210 Timer

How to Change the Length of Brine and Rinse Time:

The group of holes between the last pin in the pause section and the second group of pins determines the length of time that your unit will brine and rinse (2 min. per hole).

To change the length of brine and rinse time, move the backwash group of pins to give more or fewer holes in the brine and rinse section. Number of holes times two equals brine and rinse time in minutes.

How to Change the Length of the Backwash Time:

The group of pins after the last hole in the brine and rinse cycle determines the length of time that the unit will backwash (2 min. per pin).

To change the length of backwash time, add or remove pins at the higher numbered end of this section. The number of pins times two equals the backwash time in minutes.

How to Change the Length of Rapid Rinse:

The second group of holes on the program wheel determines the length of time that your water conditioner will rapid rinse (2 min. per hole).

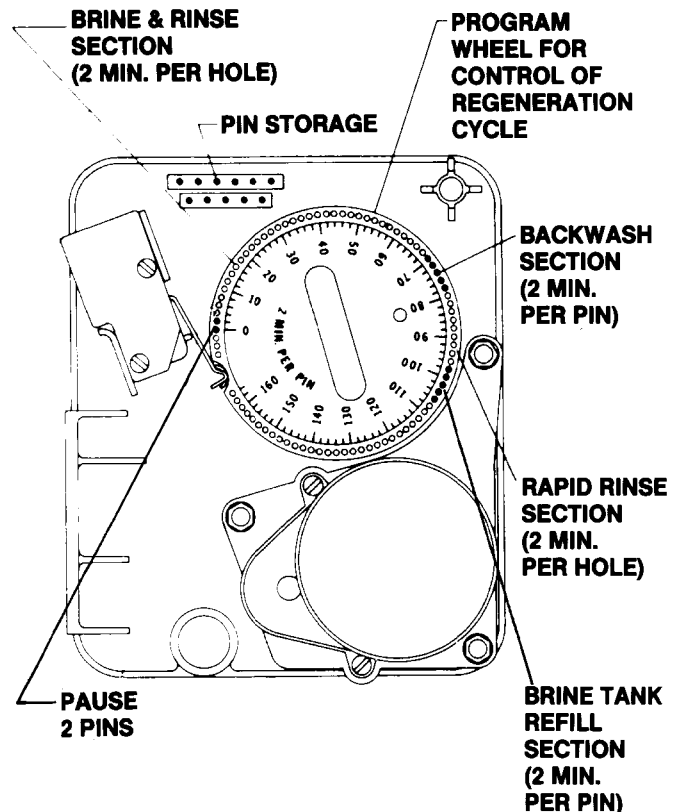

To change the length of rapid rinse time, add or remove pins at the higher numbered end of this section as required. The number of holes times two equals the rapid rinse time in minutes.

How to Change the Length of Brine Tank Refill Time:

The third group of pins in the program wheel determines the length of time that your water conditioner will refill the brine tank (2 min. per pin).

To change the length of refill time, add or remove pins at the end of the third group of pins as required. The number of pins times two equals the refill time in minutes.

The regeneration cycle is complete when the outer microswitch drops off the last pin at end of the brine tank refill section. The program wheel, however, will continue to rotate until the inner microswitch drops into the notch on the program wheel.

MODEL 3900 UP-FLOW

Service Assemblies

60036-02	1800 Brine Valve See Illustration Page 12	60131	3900 Upper Seal Kit See Illustration Page 6
1..... 11772	Spring	2.....10368	Spacer
1..... 11774	Retaining Ring	5.....10369	Spacer - Port
1..... 18713	Brine Valve Body	8.....11720	Seal
1..... 16497-01.....	Brine Stem Assembly		
1..... 16498-01.....	Stem Guide Assembly	60132	3900 Lower Seal Kit See Illustration Page 6
60272	1800 Injector Assembly See Illustration Page 12	4.....16068	Seal
4..... 12473	Screw - Hex Hd.	2.....16069	Spacer - Narrow
1..... 15127	Injector Throat	1.....16070	Spacer - Wide
1..... 15128	Injector Nozzle		
2..... 15246	O-Ring - 116	60057-01	3900 Upper Drive Motor Assembly - 115 V. See Illustration Page 8
1..... 16340-01.....	Injector Body	4.....10302	Insulator- Switch
1..... 16341-01.....	Injector Cover	3.....10872	Screw - Hex Hd.
60106-10	3900 Upper Piston Assembly See Illustration Page 6	1.....11080	Screw - Flat Hd.
1..... 14818	Clip Piston Rod	3.....10218	Switch
1..... 14922	O-Ring - 035	2.....10300	Screw - Hex Hd.
1..... 15125	Piston Rod	1.....15120	Bracket - Motor Mounting
1..... 16337	Piston	1.....16044	Drive Motor - 115 V.
1..... 16398-21.....	End Plug Assembly	1.....16052	Bushing
		1.....17797	Bracket - Switch Mounting
		2.....12624	Screw - Pan Hd.
60107-00	3900 Lower Piston - Hard Water By-Pass See Illustration Page 6	60058-01	3900 Lower Drive Motor Assembly - 115 V. System #4 See Illustration Page 10
1..... 14818	Clip Piston Rod	2.....10302	Insulator - Switch
1..... 16071	Piston	3.....10872	Screw - Hex Hd.
1..... 16072	Piston Rod	1.....11080	Screw - Flat Hd.
1..... 16076	O-Ring - 042	1.....10218	Switch
1..... 16398-21.....	End Plug Assembly - Gray	2.....10300	Screw - Hex Hd.
		2.....11805	Screw - Pan Hd.
60107-10	3900 Lower Piston - No Hard Water By-Pass See Illustration Page 6	1.....16044	Drive Motor - 115 V.
1..... 14818	Clip Piston Rod	1.....17797	Bracket - Switch Mounting
1..... 16082	Piston - No Hard Water By-Pass	1.....16086	Bracket - Motor Mounting
1..... 16072	Piston Rod		
1..... 16076	O-Ring - 042		
1..... 16399-11.....	End Plug Assembly - Black		

MODEL 3900 UP-FLOW

Service Instructions

PROBLEM	CAUSE	CORRECTION
1. Softener fails to regenerate.	A. Electrical service to unit has been interrupted. B. Timer is defective. C. Power failure.	A. Assure permanent electrical service (check fuse, plug, pull chain or switch). B. Replace timer. C. Reset time of day.
2. Hard water.	A. By-pass valve is open. B. No salt in brine tank. C. Insufficient water flowing into brine tank. D. Hot water tank hardness. E. Leak at distributor tube. F. Internal valve leak.	A. Close by-pass valve. B. Add salt to brine tank and maintain salt level above water level. C. Check brine tank fill time and clean brine line flow control if plugged. D. Repeated flushings of the hot water tank is required. E. Make sure distributor tube is not cracked. Check O-ring and tube pilot. F. Replace seals and spacers and/or piston.
3. Unit used too much salt.	A. Improper salt setting. B. Excessive water in brine tank.	A. Check salt usage and salt setting. B. See problem no. 7.
4. Loss of water pressure.	A. Iron buildup in line to water conditioner. B. Iron buildup in water conditioner. C. Inlet of control plugged due to foreign material broken loose from pipes by recent work done on plumbing system.	A. Clean line to water conditioner. B. Clean control and add mineral cleaner to mineral bed. Increase frequency of regeneration. C. Remove piston and clean control.
5. Loss of mineral through drain line.	A. Air in water system. B. Improperly sized drain line flow control.	A. Assure that well system has proper air eliminator control. Check for dry well condition. B. Check for proper drain rate.
6. Iron in conditioned water.	A. Fouled mineral bed.	A. Check backwash, brine draw and brine tank fill. Increase frequency of regeneration. Increase backwash time.

MODEL 3900 UP-FLOW

Service Instructions (Cont'd.)

PROBLEM	CAUSE	CORRECTION
7. Excessive water in brine tank.	<ul style="list-style-type: none"> A. Plugged drain line flow control. B. Plugged injector system. C. Timer not cycling. D. Foreign material in brine valve. E. Foreign material in brine line flow control. 	<ul style="list-style-type: none"> A. Clean flow control. B. Clean injector and screen. C. Replace timer. D. Replace brine valve seat and clean valve. E. Clean brine line flow control.
8. Softener fails to draw brine.	<ul style="list-style-type: none"> A. Drain line flow control is plugged. B. Injector is plugged. C. Line pressure is too low. D. Internal control leak. E. Service adapter did not cycle. 	<ul style="list-style-type: none"> A. Clean drain line flow control. B. Clean injector. C. Increase line pressure to 25 P.S.I. minimum. D. Change seals, spacers and piston assembly. E. Check drive motor and switches.
9. Control cycles continuously.	<ul style="list-style-type: none"> A. Missadjusted, broken or shorted switch. 	<ul style="list-style-type: none"> A. Determine if switch or timer is faulty and replace it, or replace complete power head.
10. Drain flows continuously.	<ul style="list-style-type: none"> A. Valve is not programming correctly. B. Foreign material in control. C. Internal control leak. 	<ul style="list-style-type: none"> A. Check timer program and positioning of control. Replace power head assembly if not positioning properly. B. Remove power head assembly and inspect bore, remove foreign material and check control in various regeneration positions. C. Replace seals and piston assembly.

General Service Hints For Meter Control

Problem: Softener Delivers Hard Water.

Cause could be that . . . Reserve Capacity Has Been Exceeded.

Correction: Check salt dosage requirements and reset program wheel to provide additional reserve.

Cause could be that . . . Program Wheel Is Not Rotating With Meter Output.

Correction: Pull cable out of meter cover and rotate manually. Program wheel must move without binding and clutch must give positive "clicks" when program wheel strikes regeneration stop. If it does not, replace timer.

Cause could be that . . . Meter Is Not Measuring Flow.

Correction: Check meter with meter checker.

3900 SYSTEM #4

Wiring Diagram

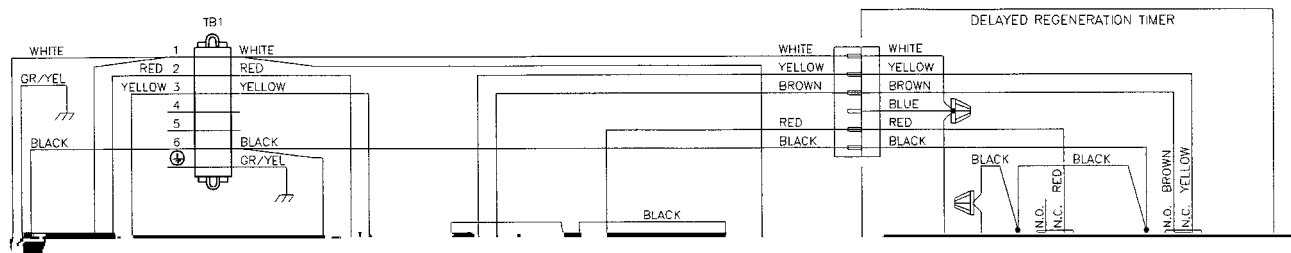

3900 SYSTEM #4 With Remote Meter

Wiring Diagram

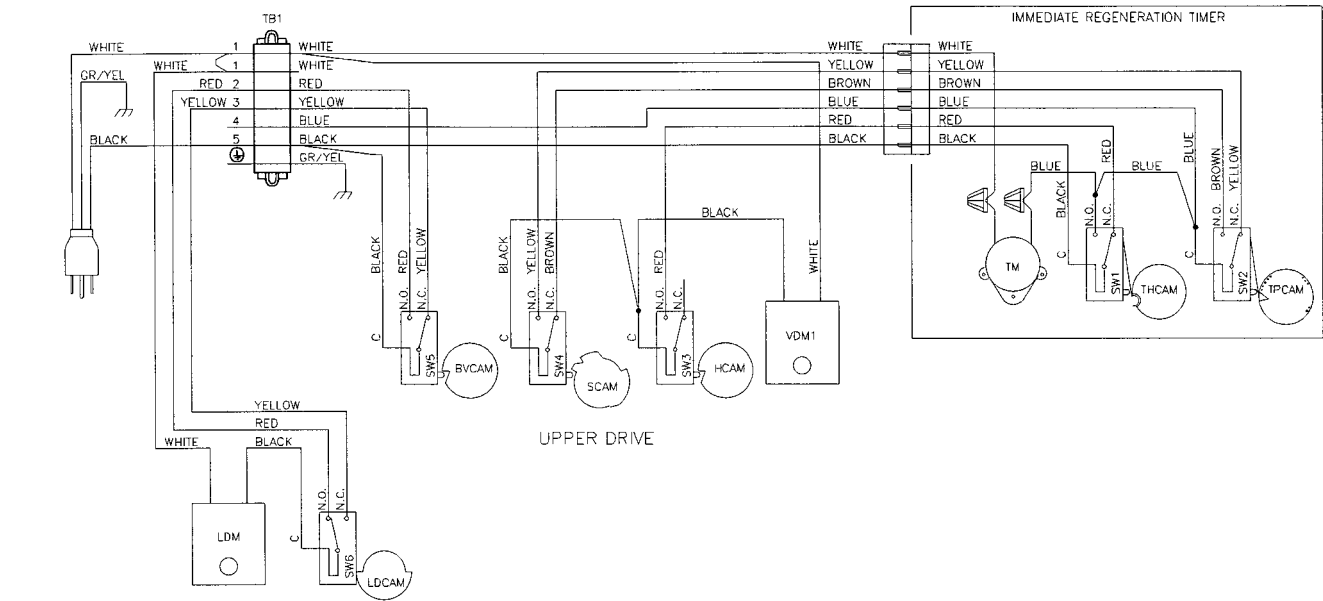

- TM - TIMER MOTOR
- VDM - VALVE DRIVE MOTOR
- LDM - LOWER DRIVE MOTOR
- SW1 - TIMER HOMING SWITCH
- SW2 - TIMER PROGRAM SWITCH
- SW3 - VALVE HOMING SWITCH
- SW4 - VALVE STEP SWITCH
- SW5 - BRINE CAM SWITCH
- SW6 - LOWER DRIVE SWITCH
- THCAM - TIMER HOMING CAM
- TPCAM - TIMER PROGRAM CAM
- HCAM - VALVE HOMING CAM
- SCAM - VALVE STEP CAM
- BVCAM - BRINE VALVE CAM
- LDCAM - LOWER DRIVE CAM

NOTE:
SINGLE TANK REMOTE METER DELAYED, OR IMMEDIATE REGENERATION

REMOTE METER WIRING

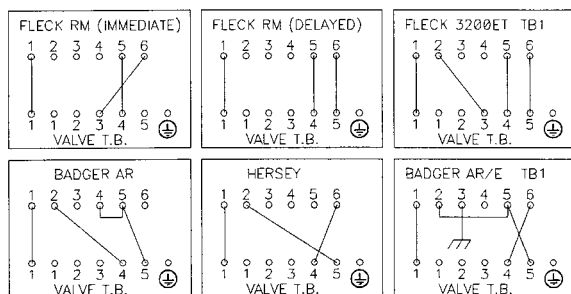

3900 SYSTEM #5

Wiring Diagram

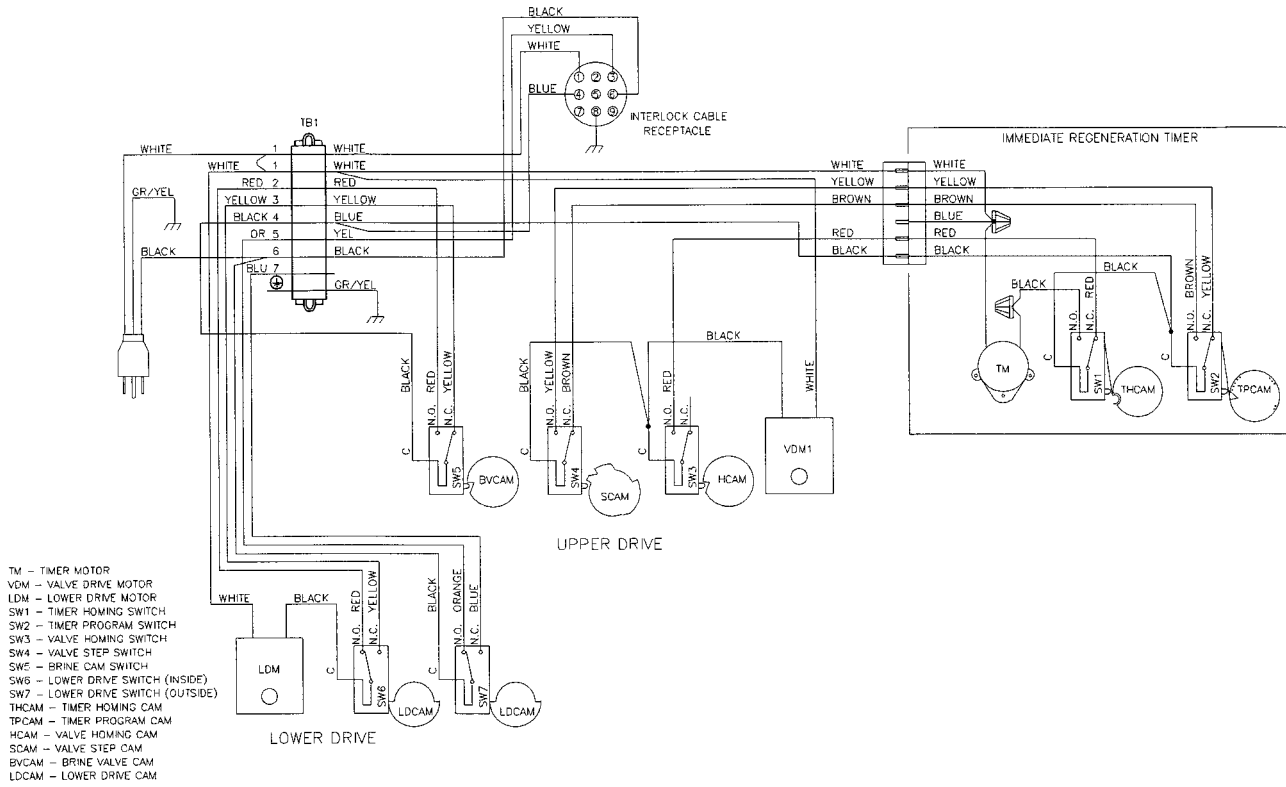

NOTE:
TWO TANK INTERLOCKED, INDIVIDUAL METER, IMMEDIATE REGENERATION.
ONLY ONE TANK IN REGENERATION THE OTHER IN SERVICE.

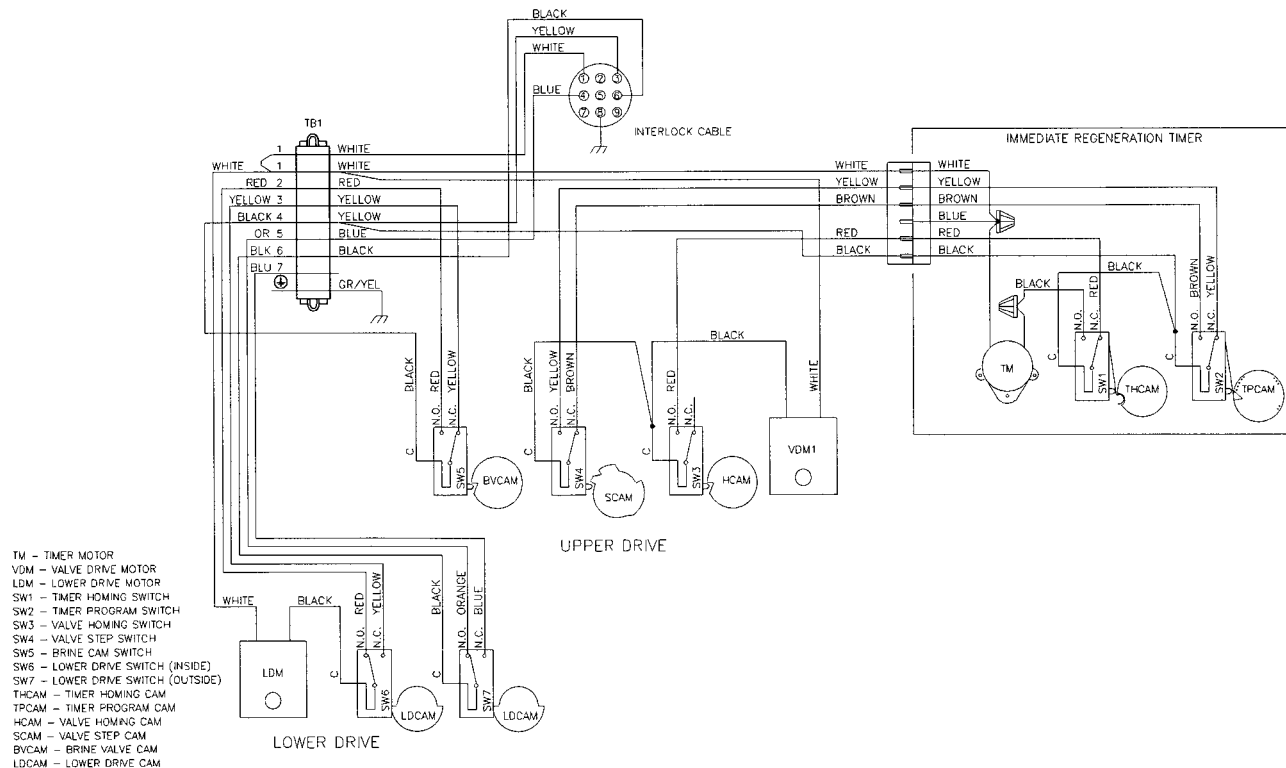

3900 SYSTEM #6

Wiring Diagram

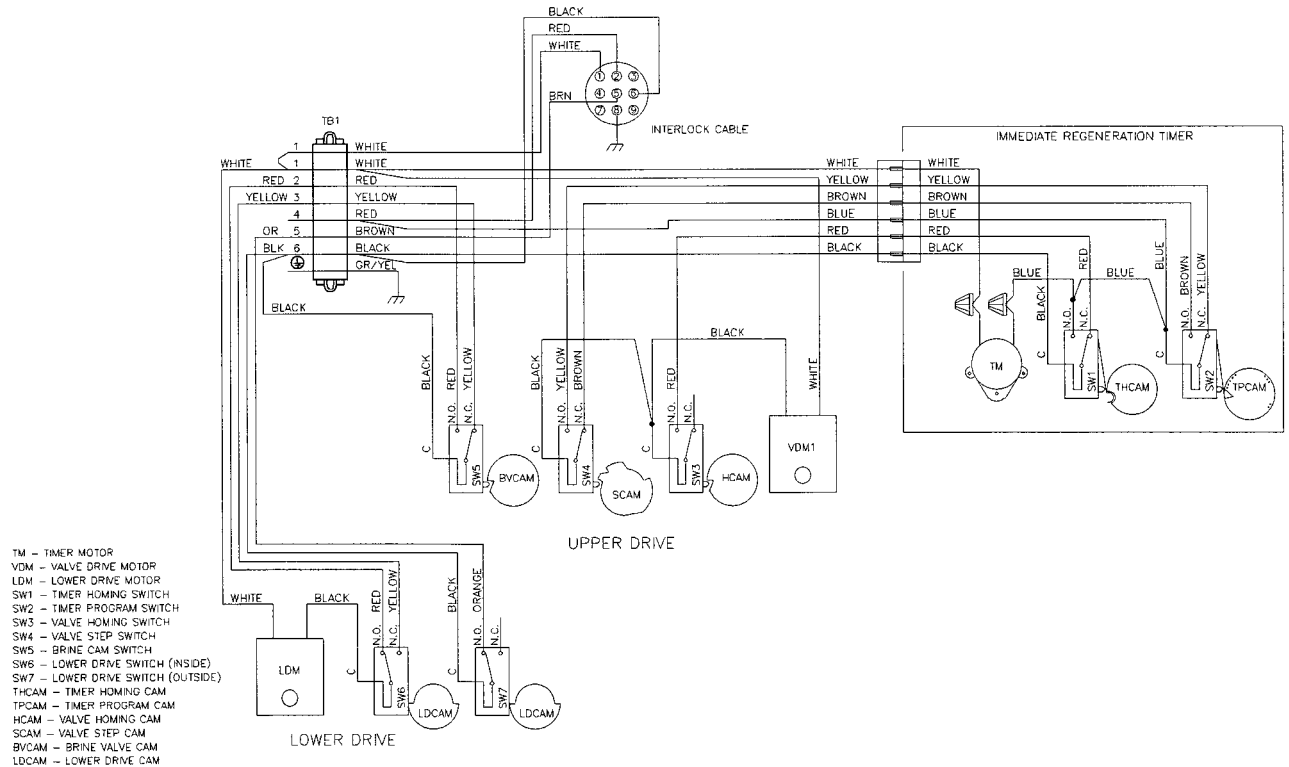
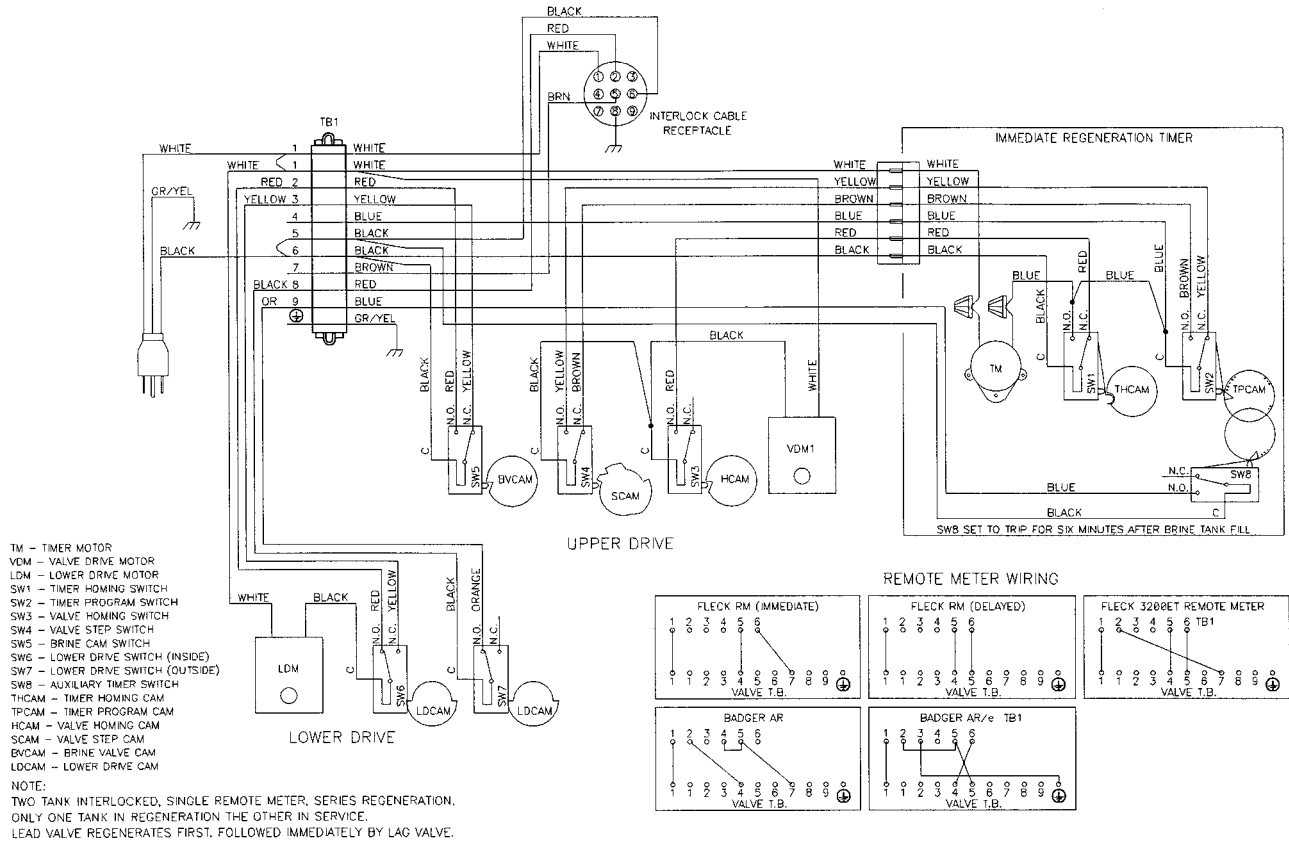

SYSTEM #7

Wiring Diagram

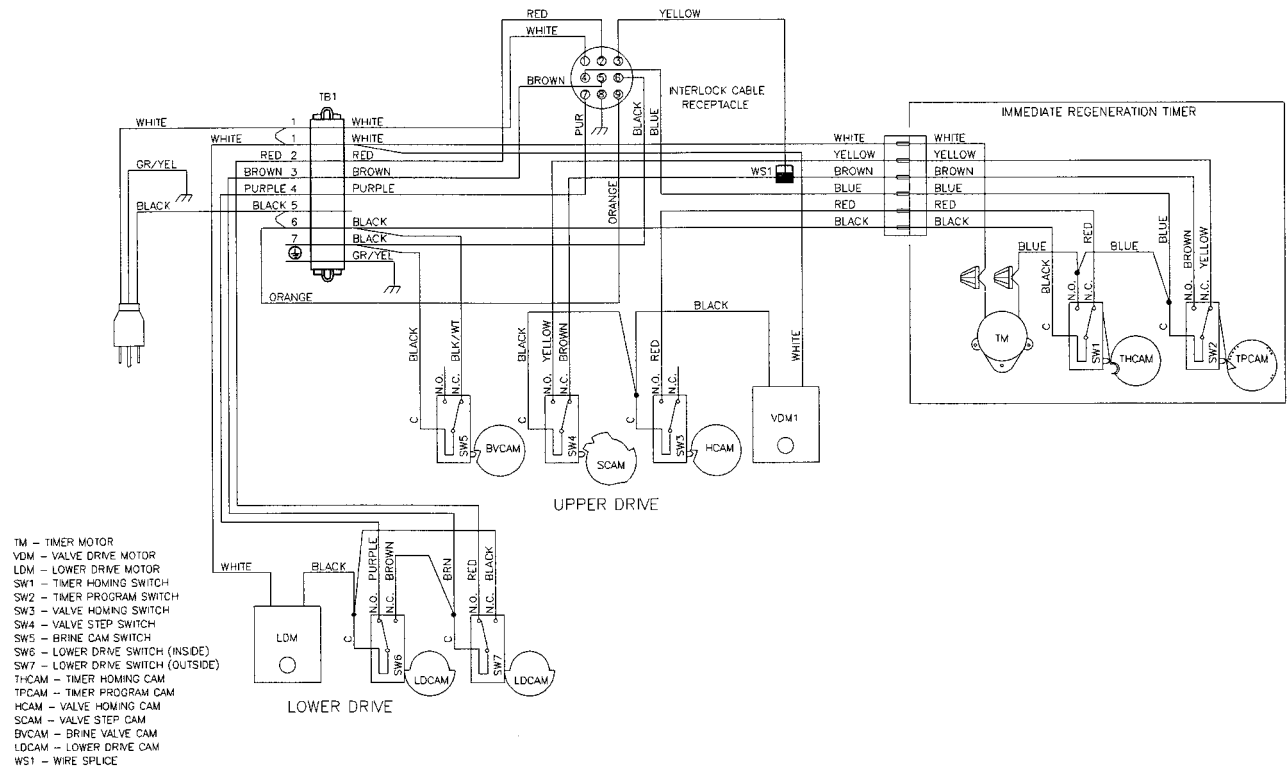
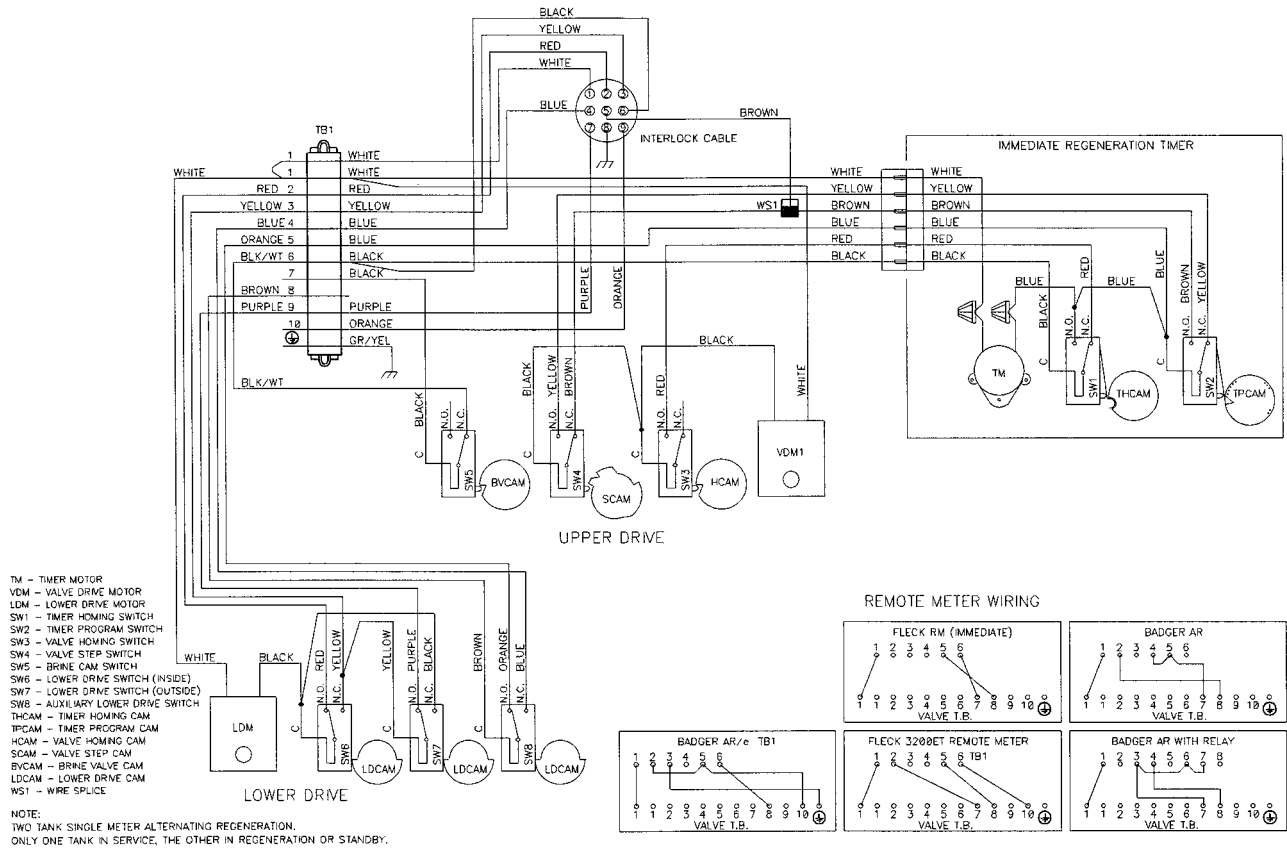

3900 MULTIVALVE SYSTEM #7

Wiring Diagram

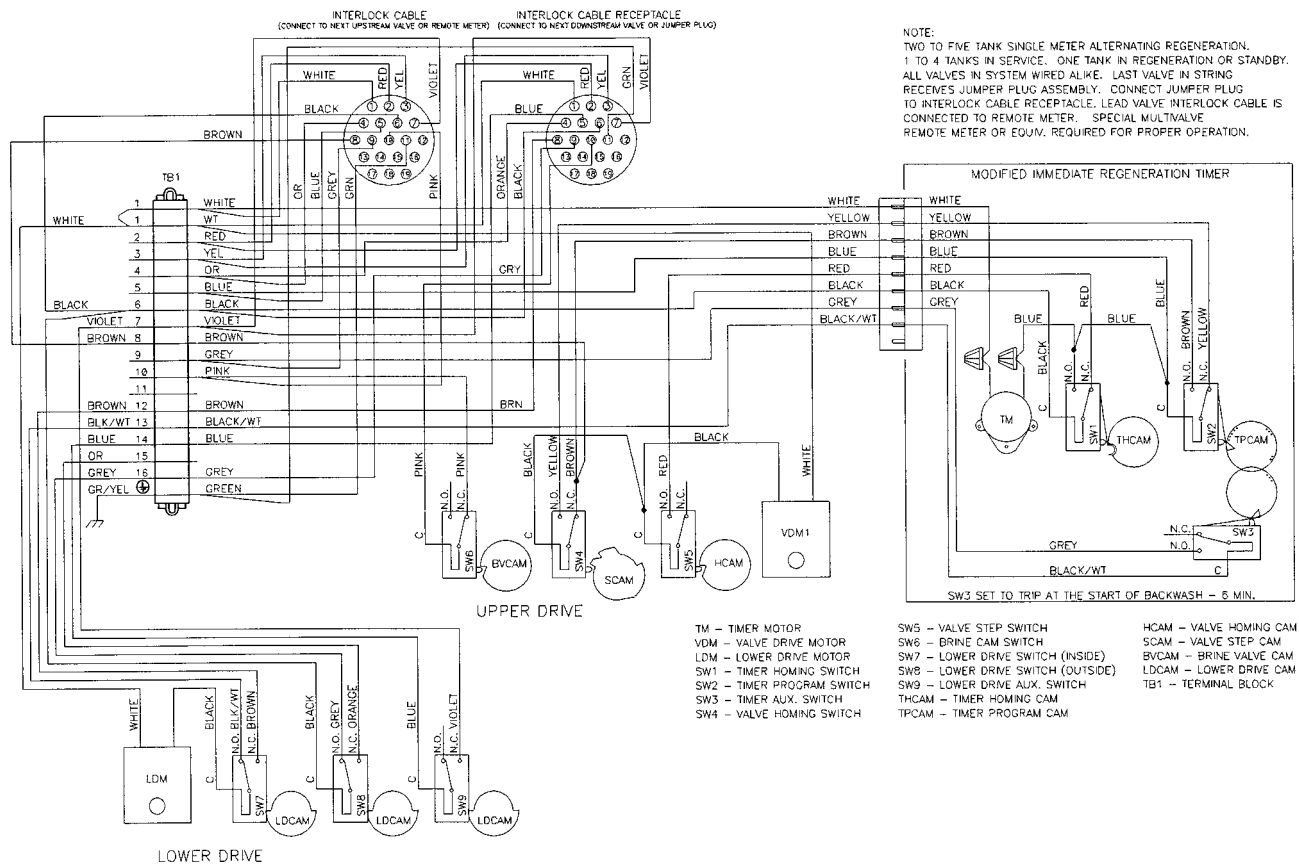

MODEL 3900 UP-FLOW

System #4 - Typical Single Tank Installation With Optional Meter

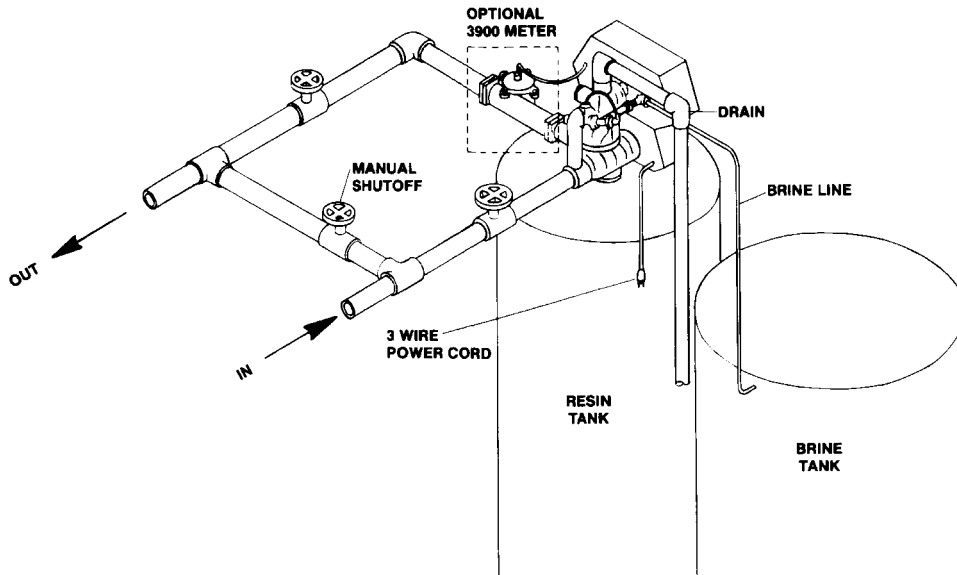

System #5 Interlock - Typical Twin Tank Installation

With Optional Meter Interlock And No Hard Water Bypass

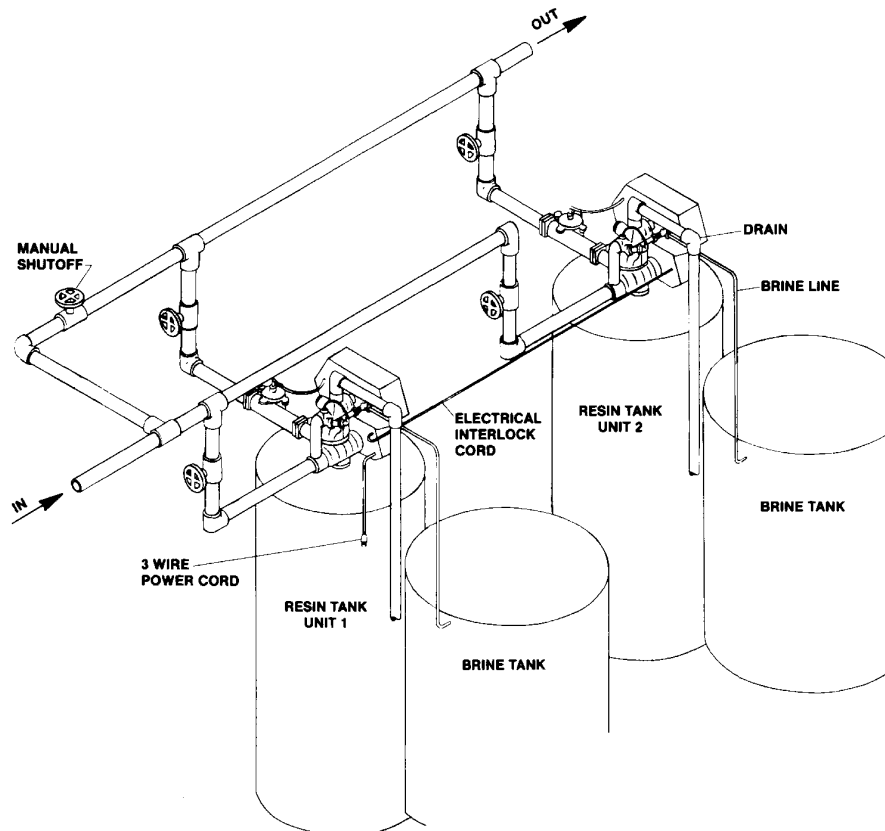

MODEL 3900 UP-FLOW

System #6 - Twin Series Regeneration

System #7 - Twin Alternator Installation

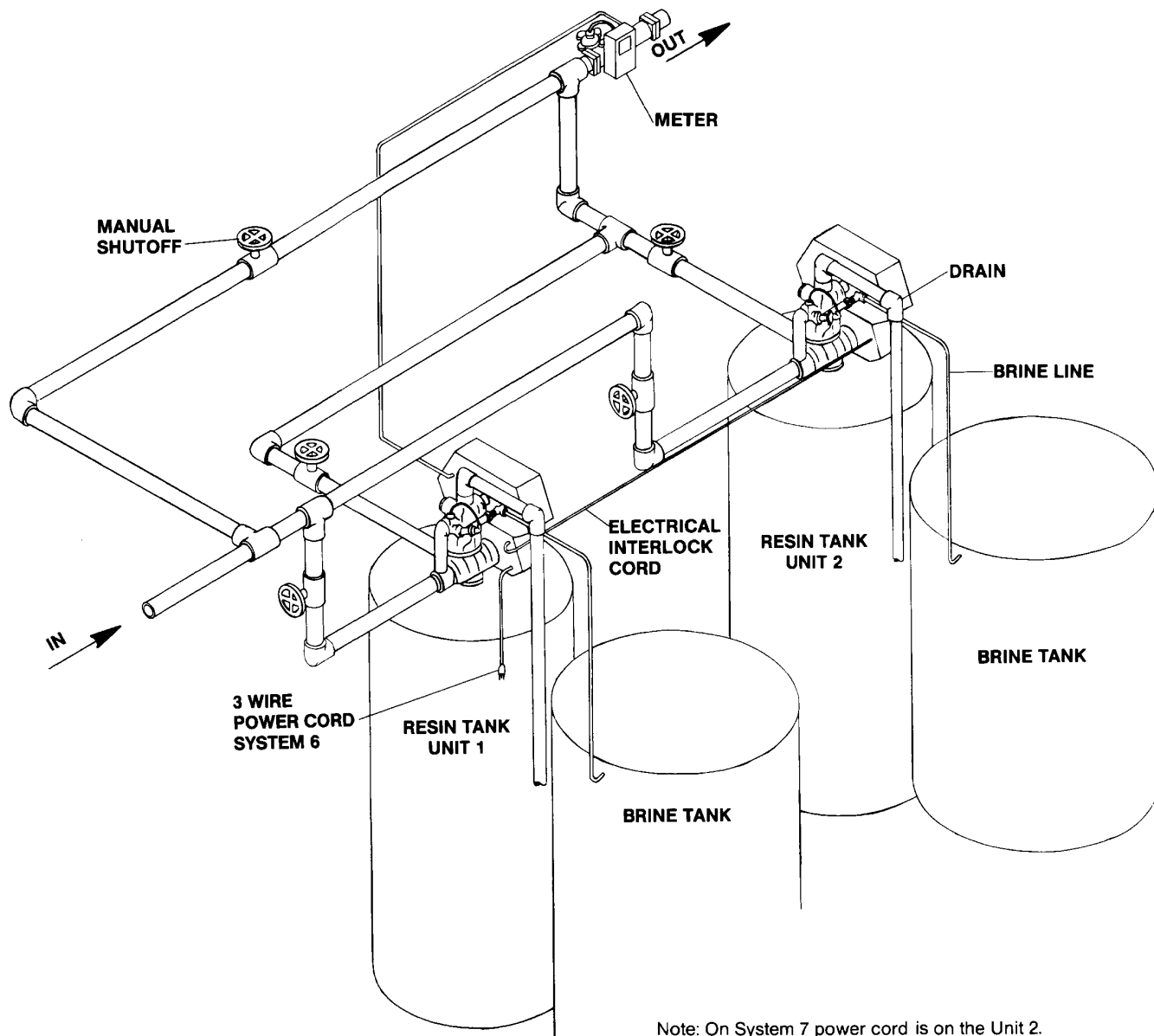

MODEL 3900 UP-FLOW

Flow Data & Injector Draw Rates

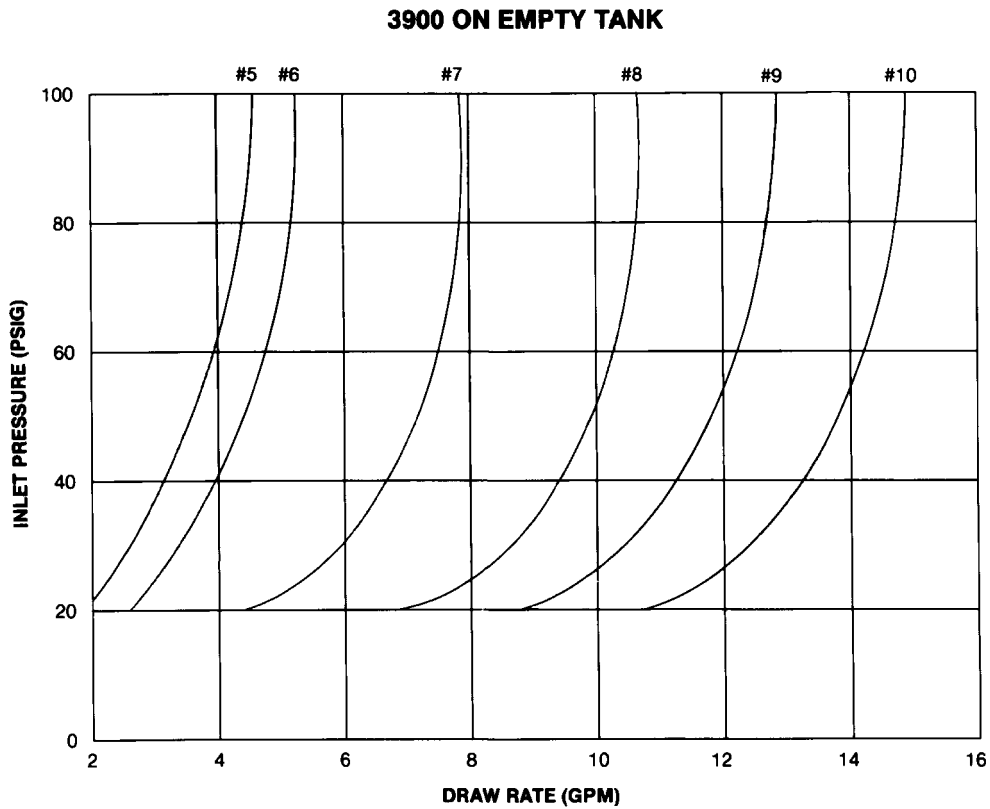
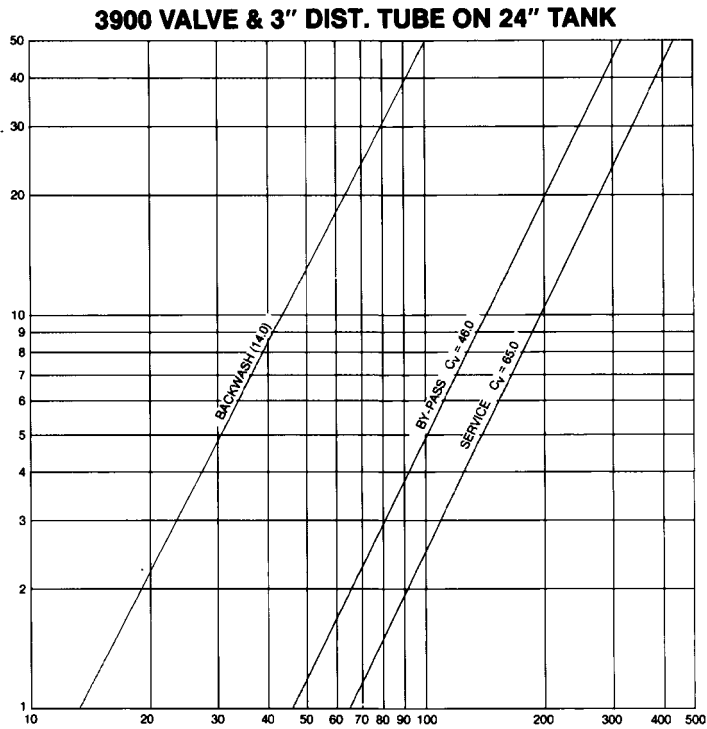

MODEL 3900 UP-FLOW

*Typical Timer Settings

Tank Dia. Volume of Resin	B/W Rate-GPM	B/W Time Min.	1800 Inj. Size	Brine and Slow Rinse Time-Minutes									Fast Rinse Time	Brine Refill Rate GPM	Brine Tank Refill Time-Minutes		
				@ 6# Per Ft ³			@ 10# Per Ft ³			@ 15# Per Ft ³					@ 6# Per Ft ³	@ 10# Per Ft ³	@ 15# Per Ft ³
				35 PSI	60 PSI	90 PSI	35 PSI	60 PSI	90 PSI	35 PSI	60 PSI	90 PSI					
24" / 10 Ft ³	15	10	4	42	30	26	68	50	46	102	76	64	10	2	6	16	26
30" / 15 Ft ³	25	10	5	36	26	24	62	42	40	96	68	64	10	5	6	10	16
36" / 20 Ft ³	35	10	6	34	28	28	58	48	48	84	68	68	10	5	8	14	20
42" / 30 Ft ³	50	10	7	36	26	26	58	44	44	92	70	70	10	10	6	10	16
48" / 42 Ft ³	70	10	8	34	34	34	56	56	56	76	76	76	10	15	6	10	14
54" / 55 Ft ³	80	10	9	40	34	34	60	50	50	90	76	76	10	15	8	12	18
60" / 70 Ft ³	100	10	10	46	36	34	68	54	52	102	80	78	10	20	8	12	18

WITH MODEL 2350 SAFETY BRINE VALVE

48" / 42 Ft ³	70	10	8	34	34	34	56	56	56	76	76	76	10	10	9	16	22
54" / 55 Ft ³	80	10	9	40	34	34	60	50	50	90	76	76	10	10	12	18	28
60" / 70 Ft ³	100	10	10	46	36	34	68	54	52	102	80	78	10	10	16	24	36

